

460

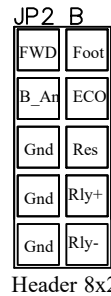

Brk=ACC
 ECO=高低速
 B_An=Brake Analog
 Foot=High level brake
 Temp=Low brake

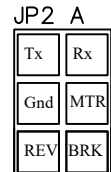
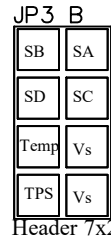
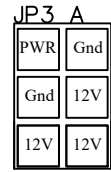
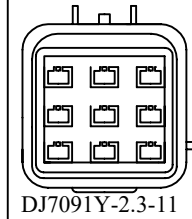
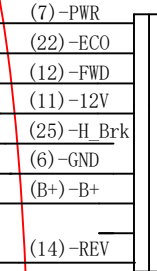
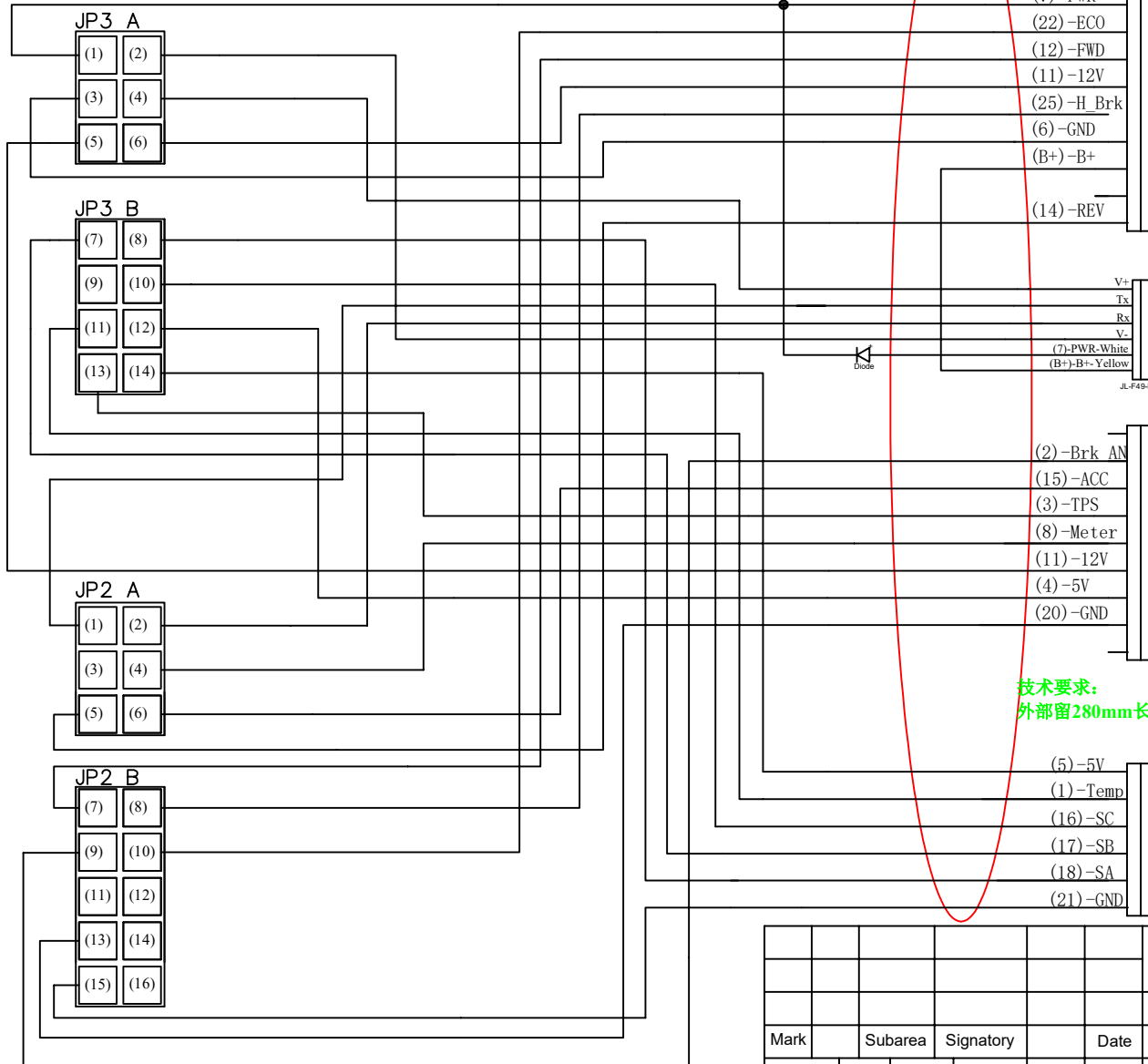

Orange REV-SW (14)	Black GND (6)	White FWD (12)
Red 12V (11)	Yellowish 12V Brake (25)	Blue ECO (22)
Yellow B+ (B+) (7)	Pink PWR (7)	

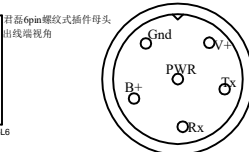
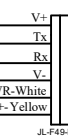

(V+) 12V Red
 (Tx) Sender Green
 (Rx) Receiver Blue
 (Gnd) GND Black
 (7) PWR White
 (B+) B+ Yellow

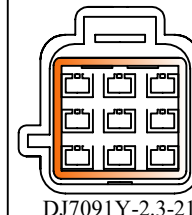
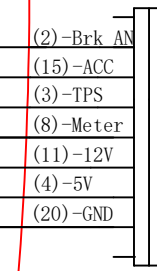

Gray Foot_SW (15)	Green Throttle (3)	
Black GND (20)	D-Gray Meter (8)	
Purple 5V (4)	Brown Brake AN (2)	Red 12V (11)

技术要求:
 外部留280mm长, 带自熄管, 对M16接口加防水处理

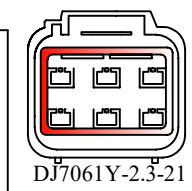
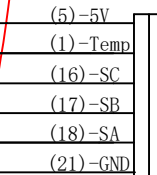

Black GND (21)	Raddle Temp (1)	Purple 5V (5)
Yellow Hall A (18)	D-Green Hall B (17)	D-Blue Hall C (16)

				18-24管铝基板KLS-N/M 小立柱无刷正弦波		KELLY CONTROLS, LLC	
Mark	Subarea	Signatory	Date	2019	KLS-NM配APT TFT750C		
Design	Fany	Standardize	Fany	modification	Number	Proportion	
Assessor	Dan						V 0112
Technics	Qijie H	Authorize	Steven	Sum			